



# Condor Operations Manual



**Alpha Systems AOA**

6180 140<sup>th</sup> Ave. N.W.

Ramsey, MN 55303

**Customer Support**

763.506.9990

[aoa@depotstar.com](mailto:aoa@depotstar.com)

The information contained in this manual is for reference only. If any information contained herein conflicts with similar information contained in the Airplane Flight Manual, the information in the Airplane Flight Manual shall take precedence.

**COPYRIGHT NOTICE**

© 2015, Alpha Systems AOA. All rights reserved.

# CONDOR

DSTR-AOA-9700K  
DSTR-AOA-9700PK  
DSTR-AOA-9700KDUAL  
DSTR-AOA-9700DPK

**OPERATIONS MANUAL**

**P# AOA-9710**

# Table of Contents

<u>Section</u>	<u>Page</u>
<b>1. Calibration and Setup .....</b>	<b>1.1</b>
1.1 Definitions .....	1.1
1.2 Restrictions and Limitations .....	1.2
1.3 Theory of Operation.....	1.3
1.4 AOA Probe Angle and In-Flight Calibration Correlation .....	1.3
1.5 Three Set-Point Calibration Overview.....	1.4
1.6 (Set-Point 1) Zero Offset Calibration (Ground).....	1.6
1.7 In-Flight Calibration Overview.....	1.7
1.8 (Set-point 2) Calibrating the Optimum Alpha Angle (OAA) .....	1.8
1.9 Invalid OAA Set Points.....	1.9
1.10 (Set-Point 3) Calibrating the Cruise Set-Point .....	1.11
1.11 Calibration Set-Point Overview.....	1.12
1.12 Identify Stall AOA Indication .....	1.12
1.13 Setting Calibrated Day / Night Brightness Levels .....	1.13
1.14 Adjusting the Audio Volume Level .....	1.14
1.15 Select Audio Type.....	1.14
1.16 Select Display Type.....	1.15
<b>2. Operating.....</b>	<b>2.1</b>
2.1 Background Information .....	2.1
2.2 System Description and Operation.....	2.1
2.3 The Indicator .....	2.2
2.4 Demonstration of Optimum Alpha Angle (OAA), Clean and Dirty.....	2.4
2.5 Demonstration of Takeoff and Climb Using AOA .....	2.5
2.6 Demonstration of Performance Based on a Constant AOA or CL.....	2.6
2.7 Demonstration of Approaches Using AOA.....	2.7
2.8 Post-Calibration Testing .....	2.10
<b>3. Continued Maintenance .....</b>	<b>3.1</b>
3.1 Continued Maintenance.....	3.1
3.2 Probe Maintenance .....	3.1
3.3 Display Maintenance.....	3.1
3.4 AOA Interface Module (IM) Maintenance .....	3.1

# 1. Calibration and Setup

## 1.1 Definitions:

**Angle of Attack (AOA)** is the difference between the airfoils cord line (a line from the leading edge to the trailing edge of the wing) and the relative wind (the inverse of the aircraft flight path).

**Coefficient of Lift ( $C_L$ )** is a relative measure of an airfoil's lifting capabilities. High lift airfoils found on typical general aviation aircraft have a curved or cambered upper surface and a flat lower surface. Airfoils found on high performance aircraft will typically have a thinner symmetrical airfoil. The  $C_L$  in both airfoils will increase with angle of attack until the stalling angle ( $C_{Lmax}$ ) is reached at which point the  $C_L$  drops off rapidly. A plot of  $C_L$  vs. angle of attack will typically show  $C_L$  increases in a straight line for both airfoils to  $C_{Lmax}$ . A key difference between the two airfoils would be the high performance airfoil will generally stall at a much lower angle of attack then the high lift airfoil.

A **Stall** is a reduction in the lift coefficient generated by a foil as angle of attack increases. This occurs when the critical angle of attack of the foil is exceeded. The critical angle of attack or **Critical Alpha Angle (CAA)** is typically about 15 degrees, but it may vary significantly depending on the airfoil design. The Stall is identified by the pilot once the AOA system is calibrated by an indication of illuminated **RED LEDs** remaining.

**Optimum Alpha Angle (OAA)** is the term Alpha Systems identifies as a set point for calibration of the AOA system at a 30% safe margin above Stall. This set point is easily identified, in flight, as **1.3Vs** and is identified by the illumination of **ALL the RED LEDs** and the **BLUE LED** segment approximately at 1/3<sup>rd</sup> up the scale of the possible display indications.

**Cruise** is the term Alpha Systems identifies as the bottom of the scale of indicated AOA set point for calibration. This calibration set point is easily identified first from the POH of the aircraft and will be  $V_a$  (maneuvering speed) Gross weight adjusted and correct for installation errors for the "air speed correction table" for that flight. **Cruise** is identified by the illumination of the last **GREEN LED** segment only.

The Alpha Systems AOA will display just the last **GREEN LED** until the angle of attack increases above the calibrated set point.

**Alpha Systems AOA**, once calibrated, will display a total range of **NO lift** indicated by **NO LEDs** illuminated, to the **Stall**, to the Optimum Alpha Angle (**OAA**), indicated by the illumination of all the **RED LEDs** and the **BLUE LED** through to the lowest indicated AOA identified and calibrated as **Cruise**, the last **GREEN LED** only, very simply put, the more LEDs that are illuminated, the more lift margin above Stall.

## 1.2 Restrictions and Limitations:

- This AOA system has not been determined to be suitable for installation in any specific aircraft by Alpha Systems. It may be installed in a type-certificated aircraft, provided that it has been determined suitable for installation by an appropriately rated mechanic by means such as field approval or as a minor alteration.
- Installation of the Alpha Systems AOA in a commuter or transport category airplane is prohibited, unless approval is given from the FAA.
- Installation of the Alpha Systems AOA as a replacement for or modification to an existing approved stall warning system is prohibited!
- The Alpha Systems AOA is required to have a placard located in plain view that must state the following: "Not for use as a primary instrument for flight."
- The AOA system may not be used as a substitution for the certified aircraft stall warning system.
- No operational credit may be taken for such items as reduced approach speed and shorter landing distances.
- The Alpha Systems AOA is not required and is intended to provide supplemental information to the pilot.

**The Alpha Systems AOA cannot be placed in the cockpit in such a manner as to interfere with the pilot's view of primary flight instruments.**

**The Alpha Systems AOA cannot be placed in the cockpit in such a manner as to obstruct the pilot's view or cause distraction.**

**The Alpha Systems AOA is a stand-alone system and does not replace any existing, primary instruments, or displays and is not considered essential for flight.**

### 1.3 Theory of operation:

Every aircraft, in flight, has an alpha range from **Stall** (highest alpha angle) to the **Cruise** angle of attack, (lowest alpha angle). All pilots manage the appropriate amount of lift for the varying stages of flight, whether it's setting up to enter the pattern, downwind, base, final, short final, flaring to touch down or knowing when to climb, maneuver, bank and turn safely.

The Alpha Systems AOA measures Angle of Attack through an AOA probe mounted solidly in a location that would sense undisturbed air, at any aircraft attitude, pitch, Slip or Skid. There are NO moving parts. This AOA probe protrudes approximately 3.5" down from the surface mounting plate. The AOA probe has 2 sense holes BOTH measuring RAM and RAM pressures. Both RAM sense ports are connected to an interface module (**IM**) through BLUE and a WHITE ¼" hoses. The electronics in the **IM** module converts pressures to digital signals. The IM module also communicates with the display(s), control, aircraft audio panel for AOA warning tones and warning messages and houses the system computer that controls the entire operational functionality.

The Alpha Systems AOA, angle of attack system is designed, once calibrated, to correlate ultra-bright LED segments to indicate the entire range of lift, from no lift (standing still), to the lowest angle of attack, the highest margin of lift above stall, **CRUISE**, using the principles and accuracies of an Angle of Attack (**AOA**) measurement system.

After calibration, a pilot can repeatedly have an indication of **Stall (Vs) to (OAA) Optimum Alpha Angle = 1.3 Vs** (30% above Stall), to the top of the Alpha Systems AOA scale at **CRUISE**, calibrated at weight corrected **maneuvering speed, Va**). After these calibration set points are entered and stored. The AOA display of the system will illuminate colored LED segments to indicate the angle of attack range from before **Stall, (No LEDs on) to CRUISE (Just the last GREEN LED on)**.

### 1.4 AOA Probe Angle and In-Flight Calibration Correlation:

The Alpha Systems Angle of Attack system displays **AOA / LIFT** measurement of the aircraft by means of an AOA probe that's mounted solidly to the aircraft. The AOA value consists of the AOA of the wing (**when in flight**) combined with the angle of the AOA probe to the chord of the wing measuring differential pressures derived throughout the entire flight envelope of the aircraft in which it's installed.

The electronics must see data within a given range to allow for a linear and full-scale reading. Due to the number of aircraft and other variables; stall angles, wing designs, coefficient of lift, mounting locations, and so on, **the probe angle will be initially set at an angle of 50 degrees to the chord of the wing. In most aircraft, starting angle would be derived from the bottom of the wing skin.**

During the calibration flight, the display will give direct feedback if the pressure values received from the AOA probe are outside of the range to give a proper full scale display indication, the system will flash combinations of background segments, **RED + BLUE**, (pressures too low) or **YELLOW + BLUE**, (pressures too high) which will indicate the direction to tilt the probe.

## 1.5 Three Set-Point Calibration Overview:

The computer system forces the calibration steps to be completed in the following order:

**(Set-Point 1) Zero-Offset Calibration:** On-the-ground, no pressure and no air flow at the AOA probe set-point. The Ground calibration wipes all values from the data base and stores a value of zero in the computer for a reference and self-check procedures. A valid **zero-offset** calibration must be entered before the computer will allow the in-flight procedures to be entered.

**(Set-Point 2) Optimum Alpha Angle (OAA):** Indicated by the blue segment. Alpha Systems AOA defines the **(OAA)** set-point by: In the **CLEAN CONFIGURATION**, first flying to identify the true and actual **Stall** speed for the current weight, CG, passengers, and baggage. Then, multiply the identified **Stall** value, by **1.3 (Vs)**. With the AOA system in the **OAA** calibration mode, fly the aircraft at the **1.3 Vs (30% above Stall)**. Maintain airspeed and trim for straight and level flight. When set, the display feedback will correlate to the **OAA** Angle of Attack of your aircraft.

**(Set-Point 3) Cruise:** Set-point is indicated by the green LED. To finish calibration, the set-point for the lowest angle of attack calibrated and displayed must be entered. After the **OAA** set point is flown and entered in the system, the in-flight **Cruise** set-point mode must be identified. This set-point is from the POH of the aircraft and will be **V<sub>a</sub>** (maneuvering speed) - gross weight adjusted and corrected for installation errors according to the "air speed correction table" for that flight. The aircraft is calibrated at a maneuvering speed (alpha). This set-point allows the system to create a needle movement range from **Cruise (green)** to **OAA (1.3Vs, blue)** and up to **Stall (1.0Vs, deep in the red), or Critical Alpha**.

Once the pilot has completed the calibration procedure, both **OAA** and **CRUISE**, the entire range of lift is displayed and can be used to identify angles of attack related to aircraft performance, such as: approach, **OAA**, **Cruise**, **Stall**, best glide and best climb, to name a few. These angles may be used accurately at any weight or density altitude, CG and bank angle every time.



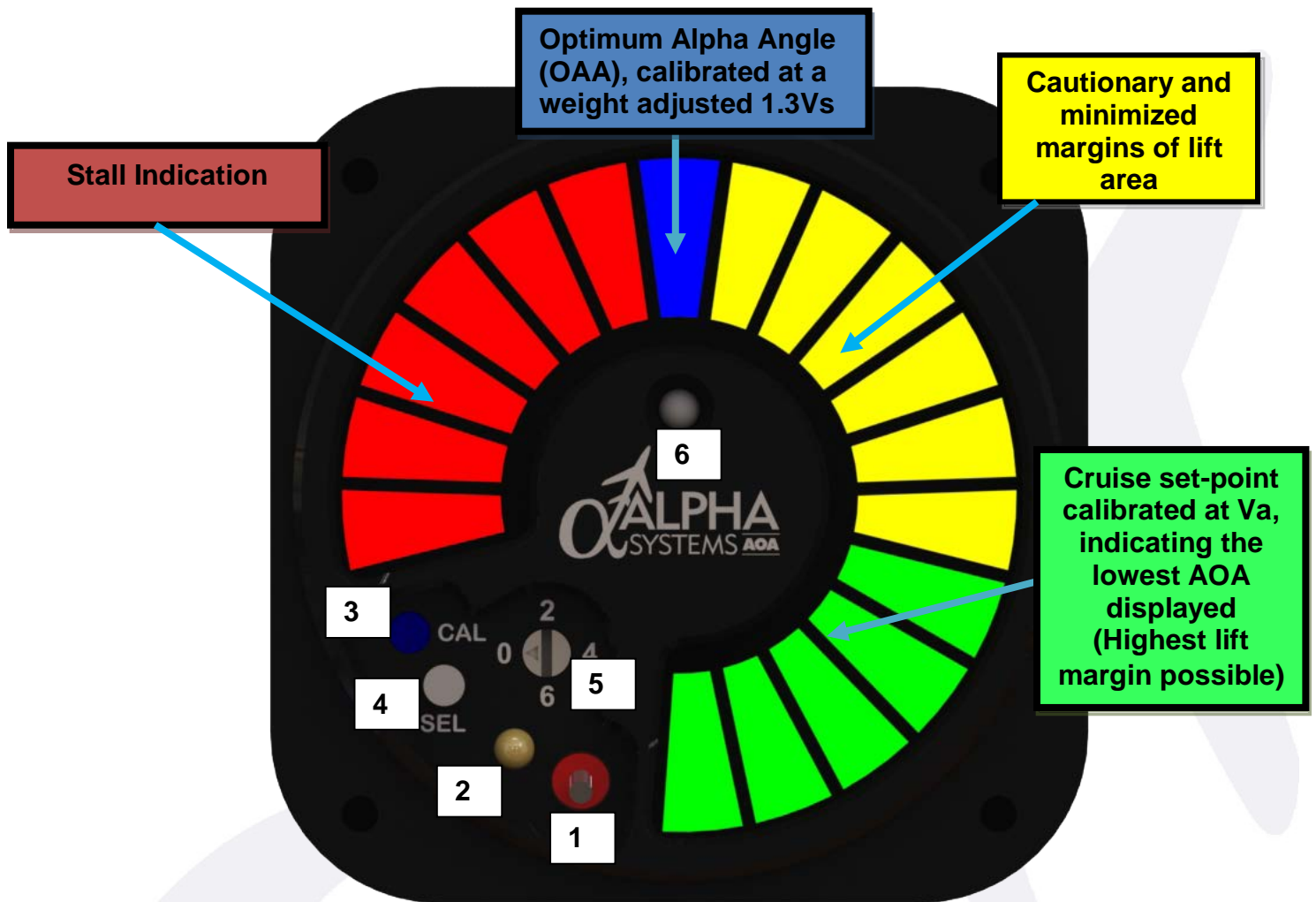

### Switch Definitions:

- 1.) **Audio Mute Switch:** Switch used for activation or deactivation of the AOA warnings to be heard from the aircraft's audio system. When in the UP position, audio warning can be heard.
- 2.) **Audio Mute LED:** Amber colored LED indication of audio ON or OFF.
- 3.) **CAL Button:** When directed in the calibration procedure, the depression of this BLUE button enters (as in "saves to memory") the value sampled.
- 4.) **SEL Button:** This is the white button protruding out from the case. When quickly pushed and released, the display will step through 16 levels of brightness. Use at corresponding rotary switch locations.
- 5.) **Rotary Switch:** An 8-position rotary switch that has a **TRIANGLE SHAPED POINTER** to indicate the switch position, **NOT THE SCREW DRIVER SLOT**. There are markings on the case at **0,2,4,6** but can be positioned in-between to gain access to the **ODD** numbered mode procedures when directed in the calibration sequences.
  - a. **Position 1** – Reset previous calibration set-points and enter **zero-offset** calibration.
  - b. **Position 2** – Enter **OAA** and **Cruise** set-point calibration.
  - c. **Position 3** – Enter day/night brightness level calibration.
  - d. **Position 4** – Enter volume level calibration. CAL button increases volume level.
  - e. **Position 5** – Enter audio type calibration. CAL button cycles through audio choices.
- 6.) **Photocell:** Detects ambient light levels and sets display brightness accordingly.

## 1.6 (Set-Point 1) Zero Offset Calibration (Ground):

The first calibration step after the system has been installed and all of the electrical connections are made is to verify electrical and zero-pressure set-points. When the unit is first turned on and all of the LED's flash, the AOA must have the **Ground** calibration procedure completed.

**ATTENTION:** *The ground calibration set-point can be reset at any time after the initial calibration. However, ALL in-flight set points will be reset and therefore must be re-entered.*

**Zero Offset calibration (Ground)** is the on-the-ground, no pressure and no air flow at the AOA probe set-point. The **Ground** calibration wipes **ALL** values from the database and stores a value of zero in the computer for a reference and self-check procedures. A valid **Ground** set-point must be entered before the computer will let the in-flight calibration start.

Follow these steps to complete the **Zero Offset Calibration (Ground)**:

- 1.) Turn the **Rotary Switch** to **position 1** with a small screw driver. The triangle on the switch should be pointing in-between 0 and 2.
- 2.) **With power OFF**, hold the **SEL button down (white button)** and power the AOA system **ON**. The AOA computer, through the aircraft's audio panel, will announce "**Set Zero Offset.**" All segments on the display will be flashing **ON and OFF** indicating the **Zero Offset** needs to be calibrated.
- 3.) Press and hold the **CAL button (blue button)** down.

**ATTENTION:** *You must complete this step to retain a zero offset set-point. Failure to press the CAL button before powering OFF, and then ON, will cause the system to revert to previous settings.*

- A.) If the **Zero Offset** set-point is accepted, the unit will announce "**Zero Offset Complete**" and will flash the **blue and the green background segments** 5 times to indicate that the ground calibration was successful and in-flight set-points can now be flown and entered.
- B.) If the **Zero Offset** set-point is not accepted, the display will continue to flash ALL SEGMENTS, and the unit will announce "**Invalid Zero Offset**".

### Failure to Complete Zero Pressure Ground Calibration

If the AOA continues to annunciate "Invalid Set-Point", the Zero Pressure value from the sensor is too high. This indicates something is wrong electrically or mechanically with the system, or something in the environment is affecting the system. The system will flag the bad zero offset and continue to repeat the "Invalid Set Point" annunciation, even if the system is powered off and on, until an acceptable Zero Pressure set point has been detected by repeating steps 1-3 above.

To isolate the failure between mechanical or electrical problems, the air hoses should be disconnected from the IF module and repeat steps 1-3 above.

If the condition persists, then the failure is electrical and the IF module should be returned for an authorized repair.

If the setting is successful, then the failure is mechanical such as a blockage in the air hoses, etc. Once the mechanical failure is fixed, repeat steps 1 through 3.

## 1.7 In-Flight Calibration Overview:

The calibration flight(s) may be conducted under §91.407 by at least a private pilot that is rated to fly the aircraft. The adjustment and tightening of the AOA probe may be accomplished by a mechanic, a person that holds a repairman's certificate for that specific aircraft or the aircraft owner if he/she holds at least a private pilot certificate under part §43.3(g) and Appendix "A" to Part §43 item (c)(26).

This procedure may be done as a single pilot operation; however, it does require your attention to be diverted away from flying the airplane. In the interest of safety we strongly recommend that you solicit the aid of someone that can perform the calibration procedure while you fly the airplane or vice versa.

Use the following outline as a guide to complete the inflight calibration:

- Review the aircraft records; ensure that the return to service entry has been made.
- Plan a flight to an area where slow flight can be performed without any undue hazards (reference § 91.303 & § 91.305).
- Review the stall recovery and minimum controllable flight procedures for your aircraft. If an inadvertent stall occurs, immediately recover from the stall per your training and the aircraft manufacturers instructions.
- Acquaint yourself with the Alpha Systems AOA "Condor" display and its controls.

### **The OAA set point calibration and the CRUISE set point calibration button entries can be practiced on the ground.**

- 1.) While the in-flight calibration can be accomplished by a solo pilot, it is advisable that the pilot flying focuses on safely and correctly achieving the calibration set points while a second person assists in performing the indicator calibration.
- 2.) Preflight and operate the aircraft as you would normally.
- 3.) When in an area where slow flight can be performed, perform clearing turns to ensure the area is clear.
- 4.) Make sure the winds are calm with little or no turbulence to allow an accurate calibration.
- 5.) Follow the aircraft procedures and slow the aircraft, **in the clean configuration**, to minimum controllable flight.
- 6.) Maintain coordination.
  - a. Maintain altitude with the pitch (use pitch trim to relieve back pressure).
  - b. Use power as needed to maintain safe slow flight.
  - c. Perform In-Flight Optimum Alpha Angle (**OAA**) calibration, fly at True **1.3Vs**.
  - d. Perform In-Flight Cruise Set Point Calibration, fly at weight corrected  $V_a$ , (maneuvering speed) use that value for the CRUISE set point.
  - e. Recover from slow flight.
  - f. Accelerate to normal cruise in level flight. We recommend a power setting for long range cruise.
  - g. Return to the airport and shut down the aircraft.
  - h. Perform exiting from the Calibration Mode on.

## 1.8 (Set-point 2) Calibrating the Optimum Alpha Angle (OAA):

Follow these steps to enter OAA calibration mode:

- 1.) Turn the power ON.
  - a. The display should flash the blue and green segments indicating Ground Calibration has been completed but the in-flight calibration must be done.
- 2.) Turn the Rotary Switch to position 2. (The triangle identifies the selection)
- 3.) Press the SEL button.
  - a. The blue segment on the display will flash three times and the unit will announce “Set-point Calibration ON” followed by “Set OAA Set-point.”
- 4.) Fly the OAA Value and when ready to enter a set-point, press the CAL button.

The unit will do one of the following:

- The AOA system accepts the **OAA** value, the display will become semi-operational and the unit will announce “**OAA Set-Point Complete.**”
- The AOA display will flash the **red and blue segments** on the display three times and announce “**Invalid OAA Set-Point.**” The set-point is too low; tip the AOA Probe 5° away from the wing (proceed to **INVALID SET POINT TOO LOW** in the troubleshooting section 5.9).
- The AOA display will flash the **blue and yellow segments** three times and announce “**Invalid OAA Set-Point.**” The set-point is too high; tip the AOA Probe 5° towards the wing (proceed to **INVALID SET POINT TOO HIGH** in the troubleshooting section 5.9).

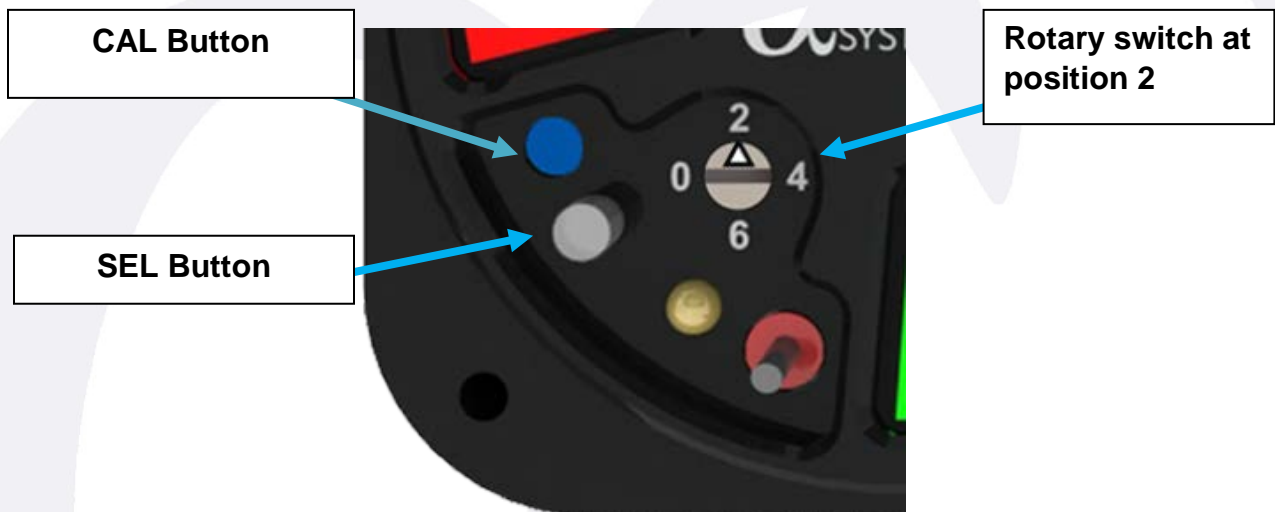

**Note:** If the AOA system indicates a bad set-point, note the display indications at the time of the button push and return to the airport. Make the necessary angle adjustments, relative to the direction of the error code, to the AOA probe. Adjust the probe in 5 degree increments. When the AOA probe angle adjustments have been made, perform the entire in-flight calibration procedure outlined in this section until you are successful.

## 1.9 Invalid OAA Set Points:

## Invalid Set-Point - Too Low



If the pilot could not get a valid **OAA** value entered during the button push and the display flashed **BLUE and RED segments**, the aircraft must be landed, and the AOA probe angle must be unpinned, rotated **away from the leading edge of the wing 5 degrees** and re-pinned, allowing the new angle to be secured and tightened. The in-flight **OAA** calibration procedure must be repeated.

Tip probe **5 degrees** away from the leading edge or increase the angle from the front side of the probe to the mounting plate.

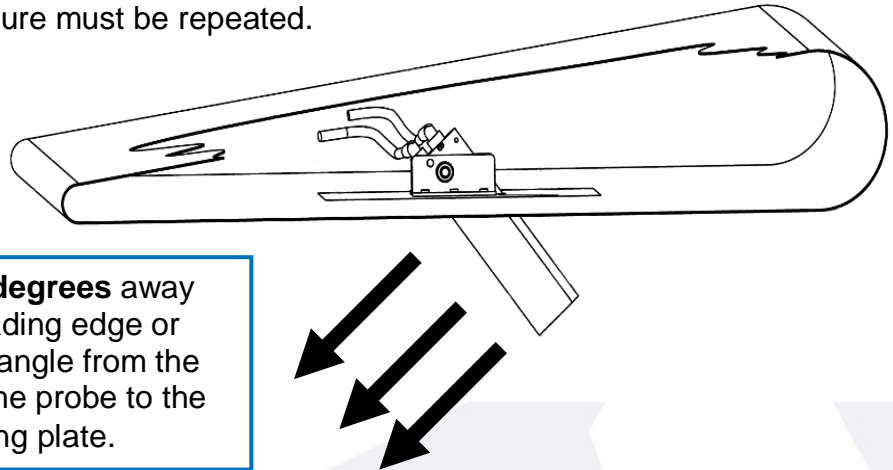

## Invalid Set-Point - Too High



If the pilot could not get a valid **OAA** value entered during the button push and the display flashed **BLUE and YELLOW segments**, the aircraft must be landed, and the AOA probe angle must be unpinned, rotated **toward the leading edge of the wing 5 degrees**, re-pinned and tightened. The **OAA** in-flight calibration procedure must be repeated.

Tip probe **5 degrees** towards the leading edge or decrease the angle from the front side of the probe to the mounting plate.

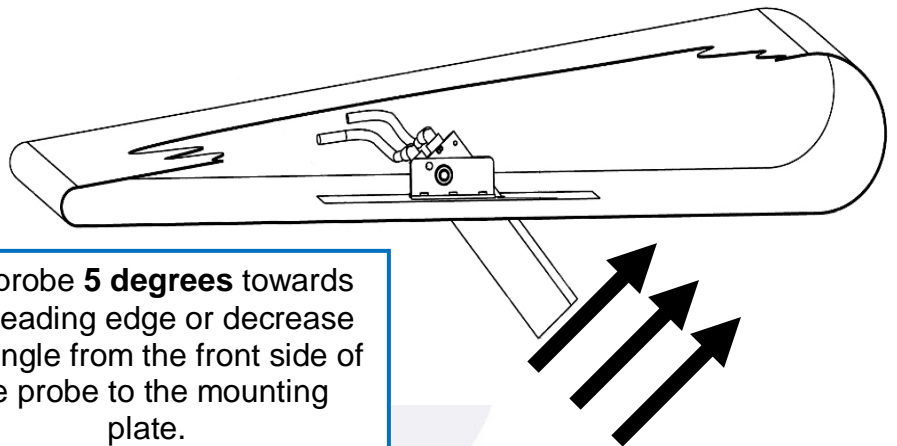

**Note:** The **CAL** Button can be pushed as many times as desired at this point to continuously attempt a new Optimum Alpha Angle (**OAA**) set-point. If the set-point is valid the display will remain operational using the new value. If the set-point is invalid, the display will no longer be operational and continue to flash the error colored LEDs.

**Note:** As long as the unit is in the **OAA CAL** routine, it will flash the **BLUE LED** twice every five to six seconds until a valid **OAA** value is entered, power is removed or the **CAL Rotary Switch** is taken out of the **OAA CAL** mode.

By turning the Rotary Switch to position 2 and pressing the SEL button AFTER the initial calibration, you can re-enter calibration mode to assign new set-points. If no new set-points are entered, the system will retain its previous settings.

(Continued)

## 1.10 (Set-Point 3) Calibrating the Cruise Set-Point:

**Attention:** *The unit must have a valid OAA value before it allows the Cruise set-point to be entered.*

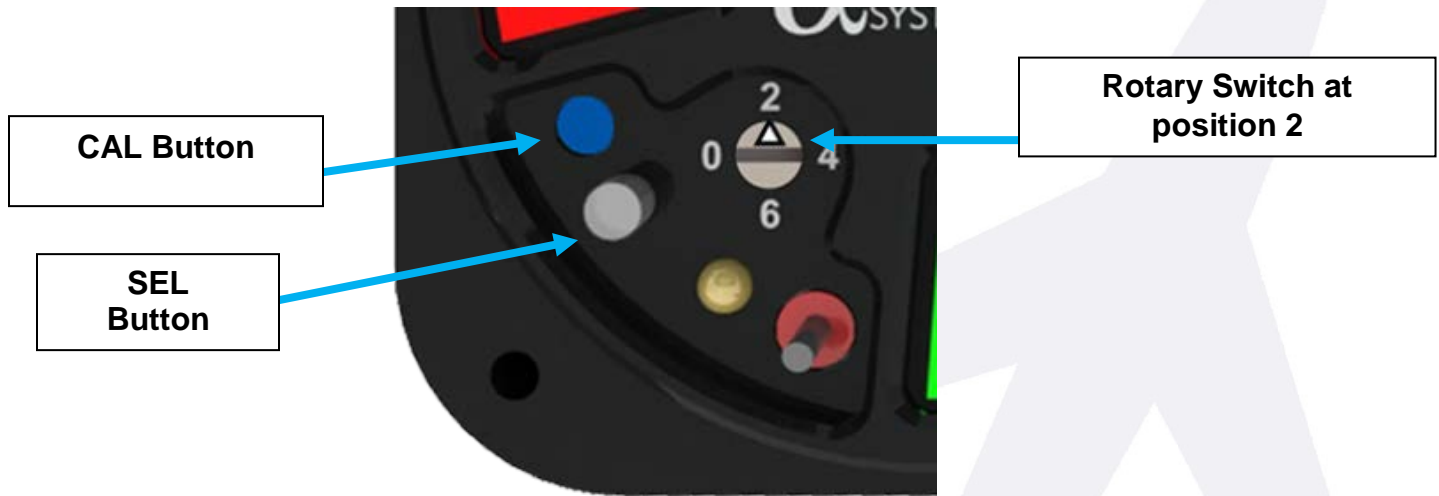

Follow these steps to set the Cruise set-point:

- 1.) To set the Cruise set-point, **with the rotary switch still in position 2**, press the **SEL** button.
  - a. The display will flash the **green** segment three times and will announce “**Set Cruise Set-Point**”. **Cruise set-point will be green LED segment**. The set-point for the lowest angle of attack calibrated and displayed, bottom of the scale, must be entered. After the **OAA** set-point is flown, identified and stored in the system, the in-flight **Cruise** set point must be entered. This set-point is identified first from the POH of the aircraft and will be **V<sub>a</sub>** (maneuvering speed), gross weight adjusted and corrected for that flight.
- 2.) Fly the aircraft at the **Cruise AOA (weight corrected, V<sub>a</sub> speed) for that flight**. Trim for straight and level flight.
- 3.) When ready, press the **CAL** button. The unit will do one of the following:
  - The needle will move to the most clock-wise position and announce “**Cruise Set-Point Complete.**”
  - Flash the **green segment** three times on the display and announce “**Invalid Cruise Set-Point,**” if out of range.

**Note:** *The **CAL** button can be pushed as many times as desired, to continuously attempt entering a new **Cruise** set-point. The pilot may have to try different speeds in order to find an acceptable set-point, or the sensor probe may need to be adjusted on the ground. The display will remain operational for both invalid and valid set-points at this point.*

**Note:** *As long as the unit is in the **Cruise** calibration routine, it will flash the **green segment** twice, every six seconds as a reminder that the unit is still in the **Cruise** calibration routine.*

**Attention:** **The values must be saved or all values will be lost!!**

If satisfied with both set-point values (OAA & Cruise) exit and **STORE** the set-points to memory:

- 1.) Turn the **Rotary Switch** to position **0**.
- 2.) Press the **SEL** button. The unit will announce “**Calibration Off**” and remain operational or the unit will announce “**Calibration Fail**” and become inoperative if one of the set-points was invalid or the calibration procedure was not completed.



### 1.11 Calibration Set-Point Overview:

Verify performance and valid set-points by repeating the identification of both **OAA** and **Cruise**. Check that set-points are functional and match previous results. The display must transition smoothly through the segments from red all the way through the green bar as the AOA decreases and you approach **Cruise** and transition back through the segments up to the red as the AOA increases to **Stall**.

### 1.12 Identify Stall AOA Indication:

Using the weight corrected Stall speed, multiply the corrected Stall speed by 1.1, or 10% (equals **1.1Vs**). Fly the aircraft at **1.1Vs** and identify the LED segment or correlate that the next movement deeper in the red is your aircrafts stall AOA indication.



### 1.13 Setting Calibrated Day / Night Brightness Levels:

**Note:** *There are 16 levels of brightness from a minimum level to a maximum level.*

- 1.) With **power OFF**, turn the Rotary Switch to position **3**.
- 2.) Hold the **SEL** button down and power the AOA ON.

The unit will announce “**Set Brightness Levels**” and the background will be illuminated.

- 3.) Cover the photocell on the AOA DISPLAY with your thumb and wait 5 seconds.

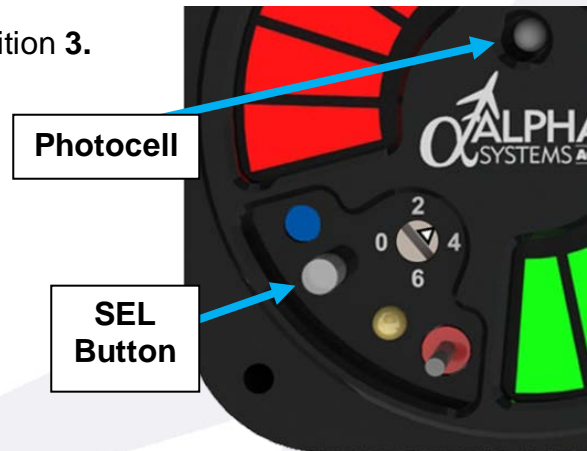

#### With the photocell covered:

- 4.) Press the brightness button repeatedly on the AOA DISPLAY until at the acceptable low ambient light brightness level.
- 5.) Wait about 5 seconds for the unit to store the calibrated setting before removing your thumb.
- 6.) Now, apply light directly to the photo diode on the AOA DISPLAY and wait 5 seconds.

#### With light on the photocell:

- 7.) Press the brightness button repeatedly on the AOA DISPLAY until it is at the acceptable high ambient light brightness level.

You'll know when at the maximum brightness level because the unit will announce “**Maximum Brightness Reached,**” and going passed it will cause the brightness of the background to return to the minimum brightness level.

- 8.) Wait about 5 seconds for the unit to store the calibrated setting before removing the light from the photocell.
- 9.) Power the system OFF.

**(Continued)**

### 1.14 Adjusting the Audio Volume Level:

- 1.) With power OFF, turn the Rotary Switch to position 4.
- 2.) Hold the **SEL** button down and power the unit on.
- 3.) Wait until the unit announces “Set Volume.”
- 4.) Now, press the **CAL** button repeatedly until the acceptable volume level.



**Note:** When at the maximum volume level, the unit will announce “Maximum Volume Reached.” When at the minimum volume level, the unit will announce “Minimum Volume Reached.”

- 5.) Power the unit OFF.

### 1.15 Select Audio Type:

- 1.) With power OFF, turn the Rotary Switch to position 5.
- 2.) Hold the **SEL** button down, power the unit on. The unit will announce “Set Audio Choice.”



#### Currently there are 4 choices of audio:

A 3 beep audio tone when the AOA increases and the needle moves to the lower part of the yellow scale (audio occurs once) or,

A 2 note, high / low audio tone when the AOA increases and the needle moves to the lower part of the yellow scale (audio occurs once) or,

A 2 note, high / low audio tone when the AOA increases and the needle moves to the lower part of the yellow scale (audio occurs once) and a feminine voice “**Too Slow**” annunciation when the needle enters the red segment (repeats 3 times) or,

A feminine voice “**Getting Slow**” (audio occurs once) when the AOA increases and the needle moves to the lower part of the yellow scale) and a feminine voice “**Too Slow**” annunciation when the needle enters the red segment (repeats 3 times).

- 3.) Press and then release the **CAL** button.

The first audio choice will sound. If the 1<sup>st</sup> audio choice is desired, power the unit OFF and it will be stored to system memory.

- 4.) If you want to select the next audio choice, press the **CAL** button again.

You will hear the 2nd audio choice. If the 2<sup>nd</sup> audio choice is desired, power the unit OFF and it will be stored to system memory.

5.) To select the next audio choice, press the **CAL** button again.

You will hear the 3rd audio choice. If the 3<sup>rd</sup> audio choice is desired, turn power OFF and it will be stored to system memory.

6.) To select the 4<sup>th</sup> audio choice, press the **CAL** button again.

You will hear the 4th audio choice. If the 4<sup>th</sup> audio choice is desired, power the unit OFF and the last selection played will be stored into system memory.

To hear all choices again, press and release the **CAL** pushbutton again and again. The system will start with the first audio choice and all selections can be repeated until the selected audio is determined and power is removed.

### 1.16 Select Display Type:

- 1.) Turn the Rotary Switch to position 6.
- 2.) Hold the SEL button down and power the Unit on.

The unit will announce "Set Display Type."

- 3.) Press the CAL button and the first display type will be previewed on the Display.

If this display type is chosen, power the system off and it will be saved to memory and the operation is complete.

- 4.) If the previous display type was not chosen, press the Cal button a second time and the second display type will be previewed. If this display type is chosen, power the system off and it will be saved to memory and the operation is complete.
- 5.) If the previous display type was not chosen, press the calibration button a third time and the third display type will be previewed. If this display type is chosen, power the system off and it will be saved to memory and the operation is complete.
- 6.) If no display type is chosen and the calibration button is pressed again, the operation will start over again with the first display type being previewed.

(End of Chapter)



## 2. OPERATING

### 2.1 Background information:

The Alpha Systems Angle of Attack system was primarily designed to improve operational safety of airplanes by increasing pilot awareness during operations at high angles of attack. Additional benefits may be reaped by identifying aircraft performance based on a fixed angle of attack or a constant  $C_L$ , such as maximum range and best glide, Stall.

**AOA: Angle of Attack** is the difference between the airfoils cord line (a line from the leading edge to the trailing edge of the wing) and the relative wind (the inverse of the aircraft flight path).

**$C_L$ : Coefficient of Lift** is a relative measure of an airfoil's lifting capabilities.

**$C_{Lmax}$ : Coefficient of Lift Maximum** is the angle of attack which if exceeded will cause the airfoil to stall.

**$C_D$ : Coefficient of Drag** is a measure of total drag, induced and parasite drag.

**$C_L/C_D$ : Coefficient of Lift over Coefficient of Drag** is a ratio between lift and drag.

**$C_L/C_D$  Maximum:** is the maximum lift-to-drag ratio at which maximum range and maximum glide distance will be found for propeller airplanes.

### 2.2 System Description and Operation:

The Alpha Systems AOA, “CONDOR” electronic angle of attack system measures pressure at two points on a AOA probe and conveys those pressures, via AOA sense lines, to the AOA interface module. The AOA interface module converts those pressures into an electronic signal that is transmitted to the display. The display interrupts the signal and turns on the appropriate Colored bars to convey the angle of attack information to the pilot. In addition to the visual display the AOA interface module can connect to the aircrafts audio panel and sound an alert for a high Angle of Attack as a warning tone.

The Alpha Systems AOA, angle of attack system draws a minimal current of less than approximately ¼ amp. (250mA) of electrical power. For the system to operate correctly, it must be supplied electrical power within a range of 10 to 28VDC, be calibrated correctly and the orifices on the AOA probe must be kept clear of any obstructions, be mounted securely in clean air flow.

Probe heat is an option and if installed requires approximately seven amps of electrical power at 12 or 28VDC to operate. To extend the life of the probe heat element it is recommended that the probe heat not be used for prolonged periods while on the ground.

## 2.3 The Indicator:

18 LED's on the display are color coded and will illuminate with additional available lift. The Bar Graphs are linearly proportional, **once calibrated**, to the angle of attack for the aircraft.

- **Green** colored bars indicates normal operations or cruise, the angle of attack is low, no worries.
- **Yellow colored** indicates caution; the angle of attack is relatively high. If not intentional take action to reduce the angle of attack, sit up and pay attention.
- **Blue bar** is the defining LED that Identifies Optimum Alpha Angle (**OAA**) see definition
- **Red colored bars** means the angle of attack is too high. Take immediate action to reduce the angle of attack such as performing a stall recovery procedure, you are in dire straights.



### Optimum Alpha Angle

Optimum alpha angle (**OAA**) is achieved during an in flight calibration maneuver with the pilot taking the aircraft to altitude. **A.)** Identify the true stall speed for that flight **B.)** Take the stall speed and multiply by 1.3 Vs **C.) Fly the aircraft trim for straight and level.** The pilot is to fly the aircraft at **OAA**, calibrating at that AOA, the display will than show: **All Red plus Blue** if the computer accepts the value for OAA.

### Cruise Indication

After entering of the "**Cruise**" set point (the last green LED on the bar graph), when the aircraft is in cruise (angle of attack), all LED's will turn off and the final Green LED will remain on The CRUISE set point is calibrated when the aircraft is flying at 1.8 Vs or Va (maneuvering speed).

### Notes:

- 1.) Actual colored segments on the display will indicate appropriate color when on and clear or no color when off.
- 2.) Display shown with full segments on

**Max Climb Angle**

Is at the second Yellow colored segment, when all Red, Blue and the 2 Yellow segments are all ON, is the indication of that aircrafts maximum angle of attack that allows continued climb.

**Stall Indication**

After the calibration is complete, the pilot will identify which Red segment identifies the “Stall” angle of attack for his or her aircraft. The corresponding number of Red segments of the Stall is dependant on the coefficient of lift and the angle of attack for each airplane. Once identified, that number of Red segments will always indicate the aircrafts stall.

**LED Brightness Control Switch**

A.) This button is at the bottom right of the bar graph and when depressed and released, repeatably, will step through 16 levels of brightness. When the maximum brightness level is reached, the brightness returns to the minimum and steps up each time the button is depressed

**B.) Auto Brightness Photo Cell**

The photo cell is at the top of the AOA display automatically detects the ambient light and will switch from “day time” brightness preset to “night time” brightness presets automatically.

**Audio Control Switch**

This switch, when turned towards the LED's, turns the Audio warning tone off. The audio warning tone comes ON when the angle of attack decreases to within 2 Yellow LED's of the Optimum Alpha Angle (**OAA**). The tone is present for a short time as the angle of attack continues to decrease. There is a beeper in the AOA interface module that generates 110 Db tone.

**Controls on the Switch Control Panel****LED Brightness Control Switch**

C.) This button is at the bottom right of the bar graph and when depressed and released, repeating will step through 16 levels of brightness. When the maximum brightness level is reached, the brightness returns to the minimum and steps up each time the button is depressed

**Calibration Button**

The calibration button is the recessed push button below the last Green LED and is marked “**CAL**”. This button is used to enter selected calibration set points (**OAA & Cruise**) during the calibration procedures.

**Audio Control Switch:** placing the switch towards the LED lights allows the high angle of attack audio alarm to be deactivated.

**Audio Off Indication:** illuminates when the audio alarm has been deactivated by the audio control switch.

**Optimum Alpha Angle (OAA):** this is identified by **All Red, Blue**. The pilot does an in-flight calibration of a slow flight maneuver equivalent to 1.3 Vs clean.

**Cruise Indication:** (Last Green segment) illuminates when the airfoil is at a low angle of attack, normally associated with cruise flight.

**Other Flight Reference Values:** Other flight values such as **Stall, V<sub>x</sub>, V<sub>y</sub>**, can be identified after the AOA has completed the calibration of **OAA** and **Cruise** setpoints. The pilot then flies the aircraft at the exact airspeed value from the pilot operating handbook that references ie: (**V<sub>x</sub>**), the corresponding number of LEDs that are illuminated equal the associated angle of attack (**VX**) from that day on, regardless of gross weight changes, density altitude and it will correspond V speed angles of attack.

## 2.4 Demonstration of Optimum Alpha Angle (OAA), Clean and Dirty:

As noted earlier, this AOA system was primarily designed to improve operational safety of airplanes by increasing pilot awareness during operations at high angles of attack. The system is calibrated with the aircraft in the **clean configuration** which means that when the flaps are lowered the display will indicate a higher angle of attack (**deeper into the red**) before stalling. It is our contention that **any operation in the red at low altitude is unsafe and if encountered immediate corrective actions should be taken to reduce the angle of attack regardless of the aircraft configuration.**

To familiarize you with the AOA indications during stalls use the following outline as a guide.

- Plan a flight to an area where stalls can be performed without any undue hazards (reference § 91.303 & § 91.305).
- Review stall recovery procedures for your aircraft.
- Acquaint yourself with the AOA indicator.
- Preflight and operate the aircraft as you would normally.
- When in an area where stalls can be performed and the air is smooth, perform clearing turns to ensure the area is clear.
- Follow the aircraft procedures and slow the aircraft, in the clean configuration (no Flaps):
  - Maintain coordination.
  - Maintain altitude.
  - Monitor the AOA indicator.
  - Slow to the stall.
  - Perform the stall recovery procedure for your aircraft.

### OBSERVED INDICATIONS:

**As the aircraft slows and the angle of attack increases note the following:**

- The LED's on the AOA indicator will extinguish, starting with the green, one at a time followed by the yellow then blue into the red.
- The High Angle of Attack Audio Warning will sound anytime the angle of attack is increased beyond the # 9 LED (THE FIRST 2 YELLOW LED's).
- The aircrafts stall warning should activate prior to the blue LED.
- When the airfoil stalls only red LED's will be illuminated. (the number of RED LED's is unique to each aircraft.)

**As the recovery progresses:**

- The AOA indicator LED's will illuminate first the blue then yellow followed by the green.
- The aircrafts stall warning will silence.
- The more LEDs that are illuminated equal more lift.

Follow the outline above again but perform the stall and recovery in the landing configuration (dirty) and observe the following:

- The LED's on the AOA indicator will extinguish, starting with the green, one at a time followed by the yellow then blue.
- The High Angle of Attack Audio Warning will sound anytime the angle of attack is increased beyond the # 9 LED (second yellow LED).
- The aircrafts stall warning will activate approximately above the Blue LED (lower yellow)
- When the airfoil stalls fewer red LED's will be illuminated then in the clean configuration.

#### As the Recovery Progresses:

- The AOA indicator LEDs will illuminate first red then blue, yellow followed by the green.
- The aircrafts stall warning will silence.
- More LEDs equal more lift (lower angle of attack).

Practice these two stalls until you become familiar with the indications on the AOA and your airspeed indicator. Since the airfoil on your aircraft will stall at the same angle of attack every time (**regardless of weight**) the AOA indications should be the same every time. To prove this try an accelerated stall in the clean configuration using the same outline as above. Notice that as the wing loading is increased in the turn the aircraft stalls at a **higher indicated airspeed** but **at the same angle of attack**.

Do you remember, ever since you were a student pilot you heard that the aircraft can stall at any airspeed, attitude or power setting? **Now** you have an instrument that will indicate the angle of attack and an impending stall or stall **every time regardless of airspeed, attitude or gross weight**.

## 2.5 Demonstration of Takeoff and Climb Using AOA.

The use of A.O.A. for takeoff and climb performance will greatly increase the pilot's awareness while operating at high angles of attack and yield safe and consistent results.

For example if you intend to perform a short field over an obstacle takeoff there are a number of factors you must consider to arrive at the proper indicated airspeed for the climb. Changing gross weight, pressure altitude, temperature will all have an affect on the indicated climb speed. On the other hand once you establish the correct angle of attack for the climb, it will be the same regardless of the factors previously mentioned.

To determine the correct A.O.A. for a climb we need a base line to start from. For this example we will figure it out for  $V_x$ , (best angle of climb). Some aircraft may use two different speeds based on the aircraft configuration, let's use the one for clearing an obstacle on takeoff. Refer to the aircraft manual to determine the configuration and airspeed for  $V_x$  considering the following factors:

- Identify actual gross weight.
- Pressure altitude, at the demonstration altitude.
- Temperature, at the demonstration altitude.
- Correct CAS for installation errors to arrive at IAS.

As before to familiarize you with the AOA indications for  $V_x$  use the following outline as a guide.

- Plan a flight to an area where the desired maneuvers may be performed without any undue hazards.
- Acquaint yourself with the A.O.A. indicator.



- Preflight and operate the aircraft as you would normally.
- When in the area perform clearing turns to ensure the area is clear.
- Maintain coordination.
- Maintain altitude.
- Use power to slow and configure for  $V_x$ .
- Maintain the indicated airspeed for  $V_x$ .
- Observe the A.O.A. indication and make a mental note.
- Return to normal flight.
- Write down the last LED illuminated.

This A.O.A. indication will be accurate for future use at any gross weight or altitude, **every time**. Also this same method may be used to determine the A.O.A. for any climb. Now try it for  $V_y$ , best rate of climb, using the procedure described above.

Document the angles of attack by the number of the last LED illuminated in a permanent record for future use (for example:  $V_x$  # 8 LED).

Now practice the use of the AOA for takeoff at airports that give you a comfortable margin. Then when you perfect the technique you can perform short field over an obstacle takeoffs safely. Use the following outline as a guide.

- Review your aircraft procedures for short field over an obstacle takeoff.
- Plan for a flight at an airport where normal takeoffs and landing may be performed.
- Preflight and operate the aircraft as you would normally.
- Perform the takeoff run as specified in the aircraft manual.
- At the specified takeoff speed rotate smoothly to the A.O.A. for  $V_x$ .

### CAUTION

**Do not over rotate or rotate too rapidly as either will cause catastrophic results.**

- When well above the obstacle decrease the A.O.A. and clean up on schedule.
- Adjust the pitch to achieve the A.O.A. for  $V_y$  and continue the climb.

### OBSERVED INDICATIONS

As the aircraft accelerates down the runway the A.O.A. indicator will start increasing the number of LEDs, starting at the red and the beyond the LED that represents  $V_x$  until rotation. When the pitch is rotated up, the A.O.A. indication will move towards  $V_x$ , adjust the pitch to maintain the  $V_x$  angle. To accelerate and clean up, the pitch is lowered thus lowering the A.O.A. and decreasing induced drag. This will allow the aircraft to accelerate so the flaps can be retracted, the changes in angle of attack can be observed.

## 2.6 Demonstration of Performance Based on a Constant AOA or $C_L$ :

As mentioned earlier the AOA may be used for identifying aircraft performance based on a fixed angle of attack or a constant  $C_L$ . For this discussion  $C_L/C_D$  Maximum indication will be identified. This is the maximum lift-to-drag ratio at which maximum range and maximum glide distance will be found for propeller airplanes.

For those of you that really get into researching, find the data on the airfoil that is installed on your aircraft. Compare the  $C_L$  at various angles of attack to  $C_D$  for your aircraft at respective angles of attack. The angle of attack that provides the maximum ratio between  $C_L$  and  $C_D$  is considered  $C_L/C_D$  Maximum.

### OR

For the rest of us, the aircraft manufacturer has already figured this out. They show it as a calibrated airspeed that will result in an angle of attack that is  $C_L/C_D$  Maximum. They had to present the information in this fashion because they did not install an angle of attack indicator on the aircraft. So to find the angle of attack for best glide calculate an indicated airspeed considering:

- Actual gross weight.
- Pressure altitude, at the demonstration altitude.
- Temperature, at the demonstration altitude.
- Correct CAS for installation errors to arrive at IAS.

As before to familiarize you with the A.O.A. indications for  $C_L/C_D$  Maximum use the following outline as a guide.

- Plan a flight to an area where the desired maneuvers may be performed without any undue hazards.
- Acquaint yourself with the A.O.A. indicator.
- Preflight and operate the aircraft as you would normally.
- When in the area perform clearing turns to ensure the area is clear.
- Maintain coordination.
- Maintain altitude.
- Use power to slow and maintain best glide speed.
- Observe the A.O.A. indication, this is  $C_L/C_D$  Maximum.

This A.O.A. indication will be correct for future use at any gross weight, altitude, **every time**.

Document the angles of attack by the number of the last LED illuminated in a permanent record for future use (for example: Best Glide # 14 LED, all red, blue, yellow, 2 green illuminated).

The methods used to arrive at this A.O.A. indication will be the same for all constant angle of attack or  $C_L$  maneuvers.

## 2.7 Demonstration of Approaches Using AOA:

A long standing rule of thumb is to use an approach speed of 1.3 times the power off stall speed in the landing configuration. Another rule of thumb is in gusty winds add 5kts. for mom and if it's really gusty add 10kts. for mom and the kids. While flying the approach at higher speeds seems to be safer, having additional speed and kinetic energy on a short runway may not be in the best interest of mom and the kids. With the means to accurately know and control the angle of attack you can fly a more stable approach and land with less kinetic energy for any given situation than flying arbitrary approach speeds. Flying an approach and landing using an AOA indicator may be a safer procedure.

The AOA has been calibrated for an angle of attack just slightly less than  $C_{LMAX}$  however an acceptable margin above that angle to fly approach and landings has not been determined. As a starting point use the aircraft manual to determine the stall speed of the aircraft at the **actual gross weight** in the landing configuration. Take that calibrated airspeed and multiply it by 1.3, 1.2 and 1.1. Then refer to the airspeed correction chart to determine the correction, if any, to convert from calibrated airspeed to indicated airspeed for the three speeds. For example:

Calibrated Stall Speed X 1.3 = App. CAS ± the correction = App. IAS  
 58Kts. CAS X 1.3 = 75.4kts. CAS + 2 kt correction = 77kts. IAS  
 58Kts. CAS X 1.2 = 69.6kts. CAS + 3 kt correction = 73kts. IAS  
 58Kts. CAS X 1.1 = 63.8kts. CAS + 4 kt correction = 68kts. IAS

For ease of discussion let's call these speeds and the resulting A.O.A. indication as 3, 2 and 1 respectively. Once the AOA angles have been identified they will be **accurate at any gross weight, every time.**

To establish angles of attack for approach using AOA indications use the following outline as a guide.

- Plan a flight to an area where stalls and slow flight can be performed without any undue hazards (reference § 91.303 & § 91.305).
- Review stall recovery procedures for your aircraft.
- Acquaint yourself with the AOA indicator.
- Preflight and operate the aircraft as you would normally.
- When in an area where stalls and slow flight can be performed and the air is smooth, perform clearing turns to ensure the area is clear.

**IF THE AIRCRAFT IS INADVERTENTLY STALLED PERFORM THE STALL RECOVERY PROCEDURE FOR YOUR AIRCRAFT.**

- Follow the aircraft procedures, slow and configure to the landing configuration:
  - Maintain coordination.
  - Maintain altitude with the pitch (use pitch trim to relieve back pressure).
  - Use power as needed to maintain flight at the first of the calculated approach speeds, 3.
  - Write down the last LED illuminated.
  - Use power as needed to slow to and maintain flight at the second of the calculated approach speeds, 2.
  - Write the last LED illuminated.
  - Use power as needed to slow to and maintain flight at the third of the calculated approach speeds, 1.
  - Write down the last LED illuminated.
  - Return to normal flight.

Document the angles of attack by the number of the last LED illuminated in a permanent record for future use (for example: 3 = 1.3 approach is # 11 LED).

**To familiarize you with the aircraft while flying practice approaches using the A.O.A. indicator as a guide please use the following outline:**

- Plan a flight to an area where stalls and slow flight can be performed without any undue hazards (reference § 91.303 & § 91.305).
- Review stall recovery procedures for your aircraft.
- Acquaint yourself with the AOA indicator.
- Preflight and operate the aircraft as you would normally.
- When in an area where stalls and slow flight can be performed and the air is smooth, perform clearing turns to ensure the area is clear.
- Follow the aircraft procedures, slow and configure to the landing configuration:
  - Maintain coordination.
  - Set the power as you would to fly a normal approach.

- Maintain altitude with the pitch until the A.O.A. approaches the 3 indication, lower and use pitch to maintain that AOA (use pitch trim to relieve back pressure).
- Fly the aircraft in the descent (straight & turning), pay attention to the flight control effectiveness.
- While the aircraft is still at a safe altitude simulate a landing flare by reducing the power to idle and increasing the angle of attack to maintain altitude until the stall (note the relative time in seconds from the start of the simulated landing to the stall).
- Perform a stall recovery.
- Climb back to the initial altitude.

**Repeat the steps above using A.O.A. indications 2 and 1. Gain experience by practicing these simulated approaches and landings using the A.O.A. indicator.**

**Some noticed observations:**

- The control effectiveness decreased with higher angle of attack.
- The higher the angle of attack the more attention has to be given to rudder inputs to compensate for adverse yaw.
- Approaches at the higher angles of attack left little time between starting the flare and stall.

Some techniques and things to consider when using an AOA to fly the approach:

- Coordinate the use of pitch and power to fly the approach and landing.
  - **Use PITCH primarily to control the A.O.A.**
  - **Use POWER primarily to control the descent rate.**  
(Keep in mind how much power it took to just maintain altitude).
- A stable approach all the way to the runway is much safer than making radical changes to the A.O.A. or descent rate once an obstacle is cleared.
- **Set a safe standard for yourself using all your experience to set a maximum AOA for any approach and do not let pressures cause you to fly an approach at too high of AOA.**
- When flying in gusty conditions fly a lower A.O.A. so that when a wind gust changes your angle of attack it does not exceed **your maximum A.O.A.**
- Having a great new system to indicate angle of attack does not change the laws of physics, use it as a new tool to keep mom and the kids safe.
- If you are planning to use the AOA to land on a postage stamp, use your excellent judgment skills so you don't have to use your exceptional pilot skills just to survive.

## 2.8 Post Calibration Testing:

A correctly calibrated Alpha Systems AOA will provide a linear increase in AOA indication as the aircraft slows. The Alpha Systems AOA is not a certified stall warning system. If the aircraft is equipped with a certified stall warning system, the following test must be performed upon completion of the system calibration. This test is to ensure that the final alert is active prior to the stall warning from the certified stall warning system in order to ensure no conflicting information is provided. Ensure during post-calibration testing that the final Alpha Systems AOA alert state is displayed prior to any stall indications.

- Plan a flight to an area where high AOA flight can be performed without any undue hazards (reference § 91.303 & § 91.305).
- Review the stall recovery procedures for your aircraft. If an inadvertent stall occurs, immediately recover from the stall per your training and the aircraft manufacturer's instructions. At no time is a stall required to correctly calibrate or operate the AOA system.
- Acquaint yourself with the Alpha Systems AOA indicator and its functions.
- Preflight and operate the aircraft as you would normally.
- When in an area and at a safe altitude that safe operation at slow flight can be performed and the air is smooth, perform clearing turns to ensure the area is clear.
- Follow the aircraft procedures and slow the aircraft, in the clean configuration (No Flaps).
- Maintain coordination.
- Maintain altitude.
- Monitor the Alpha Systems AOA indicator.
- Slow to just above the stall and ensure that the final Alpha Systems AOA alert state is displayed prior to any stall indications. If any stall warning device activates or an impending aerodynamic stall is imminent, recover immediately using the appropriate procedure for your aircraft.
- Return to normal flight.
- If the aircraft stall warning device activated prior to the final "Too slow Too slow" alert with flashing red arrow repeat the calibration procedure as described in section 4 of this Installation Manual.

**We just barely scratched the surface of aerodynamics, if you are interested in learning more may we suggest obtaining a copy of "The Advanced Pilot's Flight Manual" by William K. Kershner published by Aviation Supplies & Academics, Inc. (ASA).**

**FLY SAFE!**

**GOT LIFT?**

### 3. Continued Maintenance

#### 3.1 Continued Maintenance:

Maintenance and upkeep of the Alpha Systems AOA unit is very simple. All of the aluminum parts have been anodized for maximum protection. There are NO overhaul time requirements.

#### 3.2 Probe Maintenance:

During calibration, the probe angle was locked with the BLUE safety pin plate and secured with the probe mounting bolt. Confirm that the probe is tight; mounted securely and there are no visible cracks in the mounting plate or probe. The inspection plate screws must be secure and the mounting plate shows no sign of wear or cracking around the screw heads. If the probe plate is to be removed, assure hoses and fittings are tight and hoses are inserted completely into connectors and are not kinked. After re-installation assure probe angle is as originally mounted and re-check in-flight calibration set points and other in-flight dynamic values are at the same calibrated colored segment illumination reference points.

#### 3.3 Display Maintenance:

The Alpha Systems AOA display should be inspected to ensure the security of the display to the instrument panel or glare shield verifying mounting security. It should not be loose and all mounting screws tight. Each time the AOA is turned on, the unit illuminates each individual colored segment until all segments are on, and then turning each segment OFF. Verify each segment turns ON and OFF independently. Verify set points and the other aero-dynamic values are still identical to the calibrated illuminated color segments are as previously set.

#### 3.4 AOA Interface Module (IM) Maintenance:

Verify all electrical connectors are completely inserted and all connections are tight. Electrical wires and connections are secure and no cuts or wear is visible on the wire. The AOA Interface Module mounting screws are tight and no cracks or loose brackets are present. Hoses are inserted completely, not kinked and no wear or depressions.

Basically, if you believe that the lines may be blocked, cut or kinked, remove the lines from the AOA, IM and blow air from the cockpit **out** towards the probe. This will remove the obstruction and test the lines integrity from the inside of the cockpit out to the AOA probe mount. Verify hoses are intact with no leaks and are not restricted or kinked in any way. If there is any doubt, **DO NOT** rely the instrument and have a mechanic check on the installation or call the Alpha Systems Company.

**Verify correlation of the illuminated colored segments to aircrafts AOA.  
Recalibrate when ANY AOA probe angle changes or adjustments are  
identified or completed.**

**DO NOT BLOW INTO THE PROBE**

If the calibration is in question, **recalibrate as per manual.**

The Condor AOA display will illuminate varied colored segments with repeated responses to the same aircraft AOA after calibration. Verify as to the calibration procedures contained herein this manual. If the responses are different or don't respond in a smooth transition from the **Cruise** setpoint to **OAA**, and from **OAA** to **Stall**, or from no colored segments on the ground, a linear transition through all of the segments illuminating one by one until the **Cruise** set point is reached, (Green bar) recalibrate. If the recalibrations are unsuccessful, have the mechanic inspect ALL installation mounts, tubes, fittings, verify AOA probe holes are clear and hoses are not cut.

**If reattempts at calibrations are unsuccessful; call Alpha Systems AOA / DepotStar, Inc. for customer service.**

**763-506-9990**

**We appreciate the opportunity to provide an instrument that will aid every pilot with additional information increasing pilot awareness of lift when in flight. Alpha Systems is committed to continue supporting the GA community with innovative solutions and improvements to our Angle of Attack Systems.**

**Please tell all your friends and fellow pilots about  
Alpha Systems AOA!**