

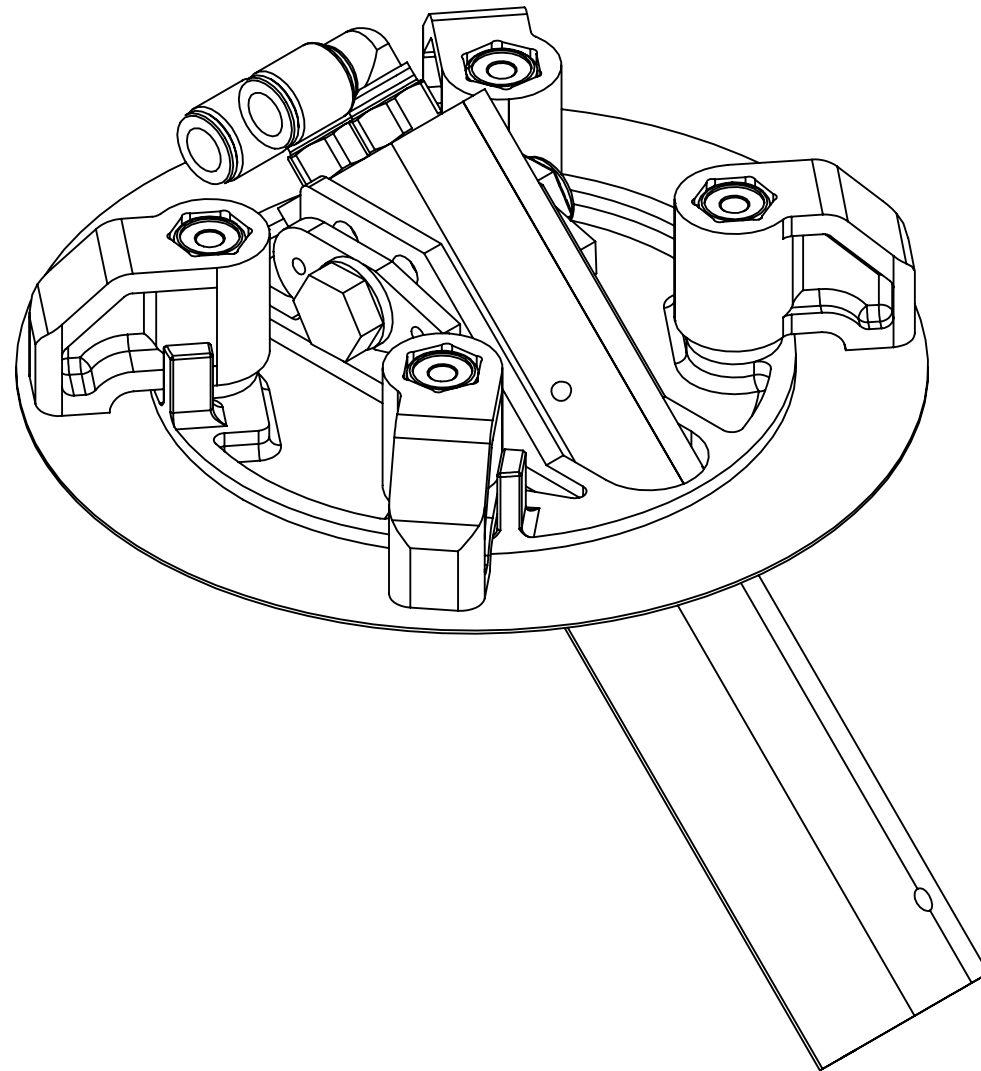

ITEM NO.	PART NUMBER	DESCRIPTION	QTY.
1	AOA-4049-1	LOCKING RETAINER	2
2	AOA-4007 - RAW SOLID	PROBE	1
3	AOA-4050-1 Clamp	CLAMP	4
4	AN4-13A	BOLT	1
5	AN364-1032A	NUT, ELSTIC STOP MS21083N3	4
6	AOA-4005	STOP NUT	1
7	AOA-4006	WASHER 1/4"	2
8	9435K360	SPRING	4
9	AOA-4046-1	MAULE BASE PLATE	1
10	AOA-4008	ELBOW TUBE 1/4"X1/8" NPT	2

REVISIONS				
REV.	DESCRIPTION	DATE	DRAWN	APPROVED
A	REDESIGN RELEASE	6/1/2011	ARV	



UNLESS SPECIFIED,
UNITS ARE IN INCHES
AND TOLERANCES ARE:
DIMENSIONS ARE IN INCHES
.X = ±.03
.XX = ±.01
.XXX = ±.005
DEG = ±1°
X/X = ±1/16

THE INFORMATION CONTAINED IN
THIS DRAWING IS THE SOLE PROPERTY
OF DEPOTSTAR. ANY REPRODUCTION
IN PART OR AS A WHOLE WITHOUT THE
WRITTEN PERMISSION OF DEPOTSTAR
IS PROHIBITED.

PRODUCT: X	
DRAWN ARV	
DATE 6/1/11	PROJECT: AOA-4046
SHEET: 1 OF 2	DESCRIPTION: MAUL PLATE ASSEMBLY
SCALE: NONE	
SIZE: B	
FINISH: *	
MATERIAL: *	PART #: AOA-4046
	A

8 7 6 5 4 3 2 1

REVISIONS				
ZONE	REV.	DESCRIPTION	DATE	APPROVED
-	-	See Sheet1	-	-

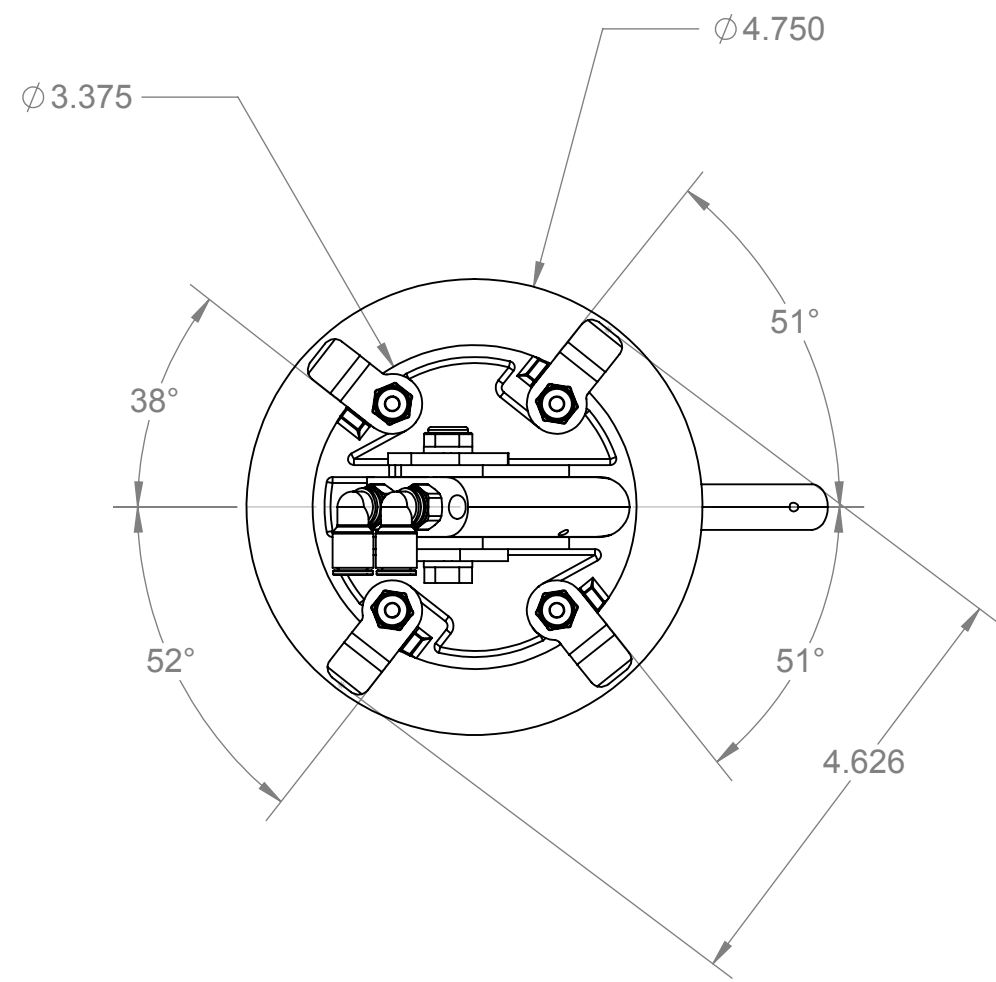

FRONT AND TOP VIEWS
1:2 SCALE

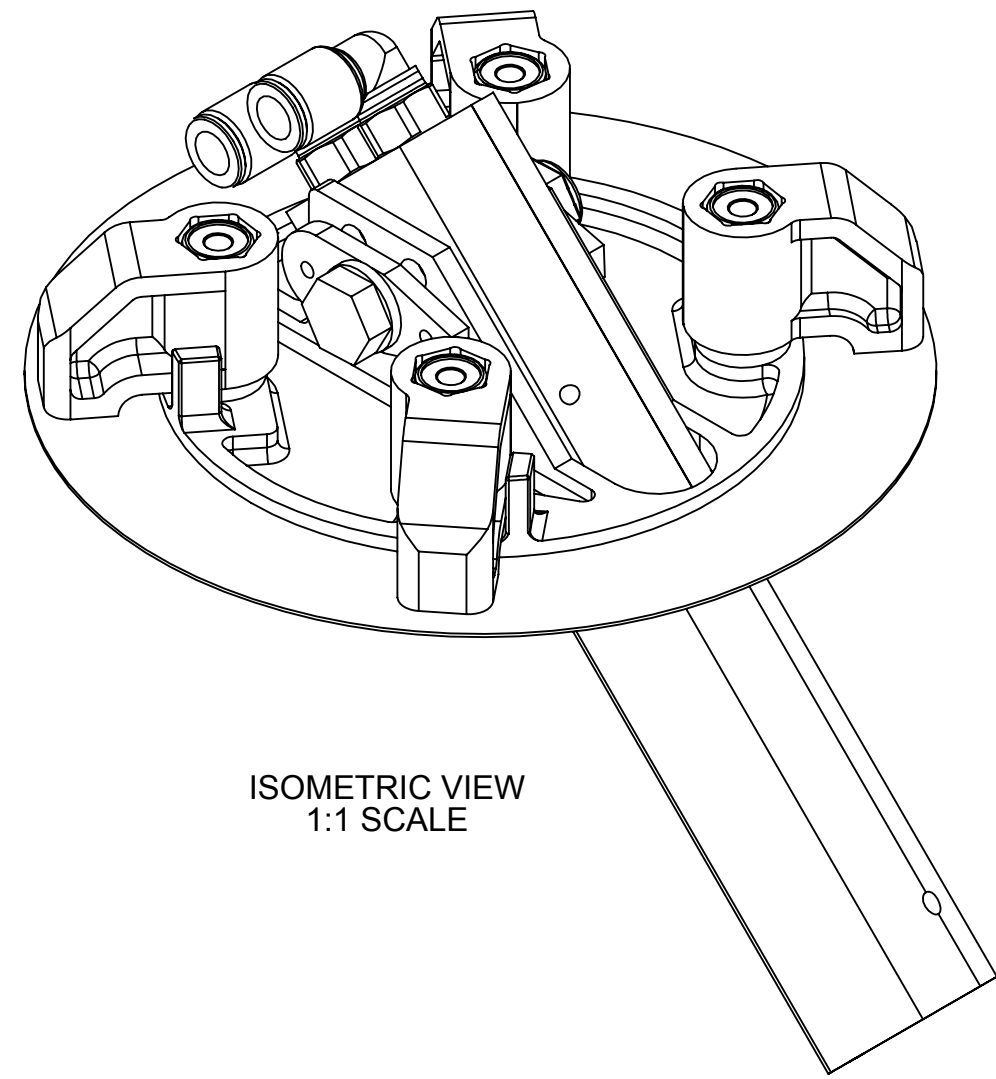

ISOMETRIC VIEW
1:1 SCALE

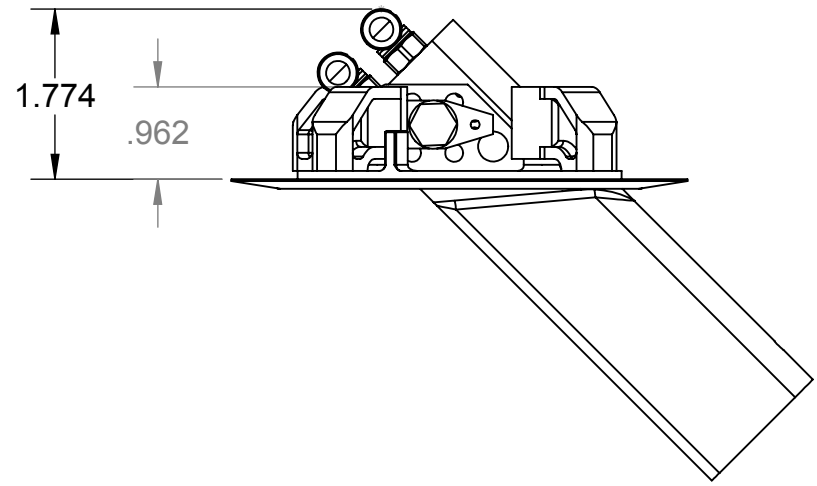

NOTE:
IF USED WITH HEATED PROBE
ALLOW AN EXTRA 1.25" TO THE
HEIGHT

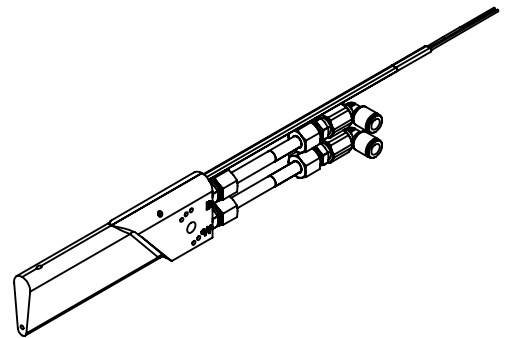

SCALE 1:4

UNLESS SPECIFIED,
UNITS ARE IN INCHES
AND TOLERANCES ARE:
DIMENSIONS ARE IN INCHES
.X = ±.03
.XX = ±.01
.XXX = ±.005
DEG = ±1°
X/X = ±1/16

THE INFORMATION CONTAINED IN
THIS DRAWING IS THE SOLE PROPERTY
OF DEPOTSTAR. ANY REPRODUCTION
IN PART OR AS A WHOLE WITHOUT THE
WRITTEN PERMISSION OF DEPOTSTAR
IS PROHIBITED.

PRODUCT: X	 PROJECT: AOA-4046 DESCRIPTION: MAULE PLATE PART #: AOA-4046 REDESIGN
DRAWN: ARV	
DATE: 6/1/11	
SHEET: 2 OF 2	
SCALE: NONE	
SIZE: B	
FINISH:	
MATERIAL:	

8 7 6 5 4 3 2 1

REV.	DESCRIPTION	DATE	DRAWN
A	RELEASE	7/11/2012	ARV

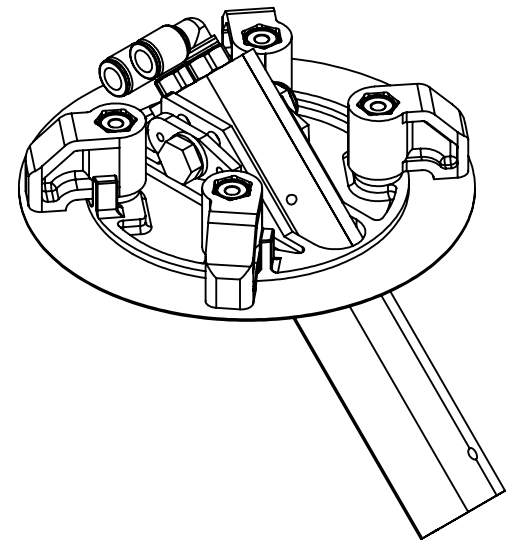
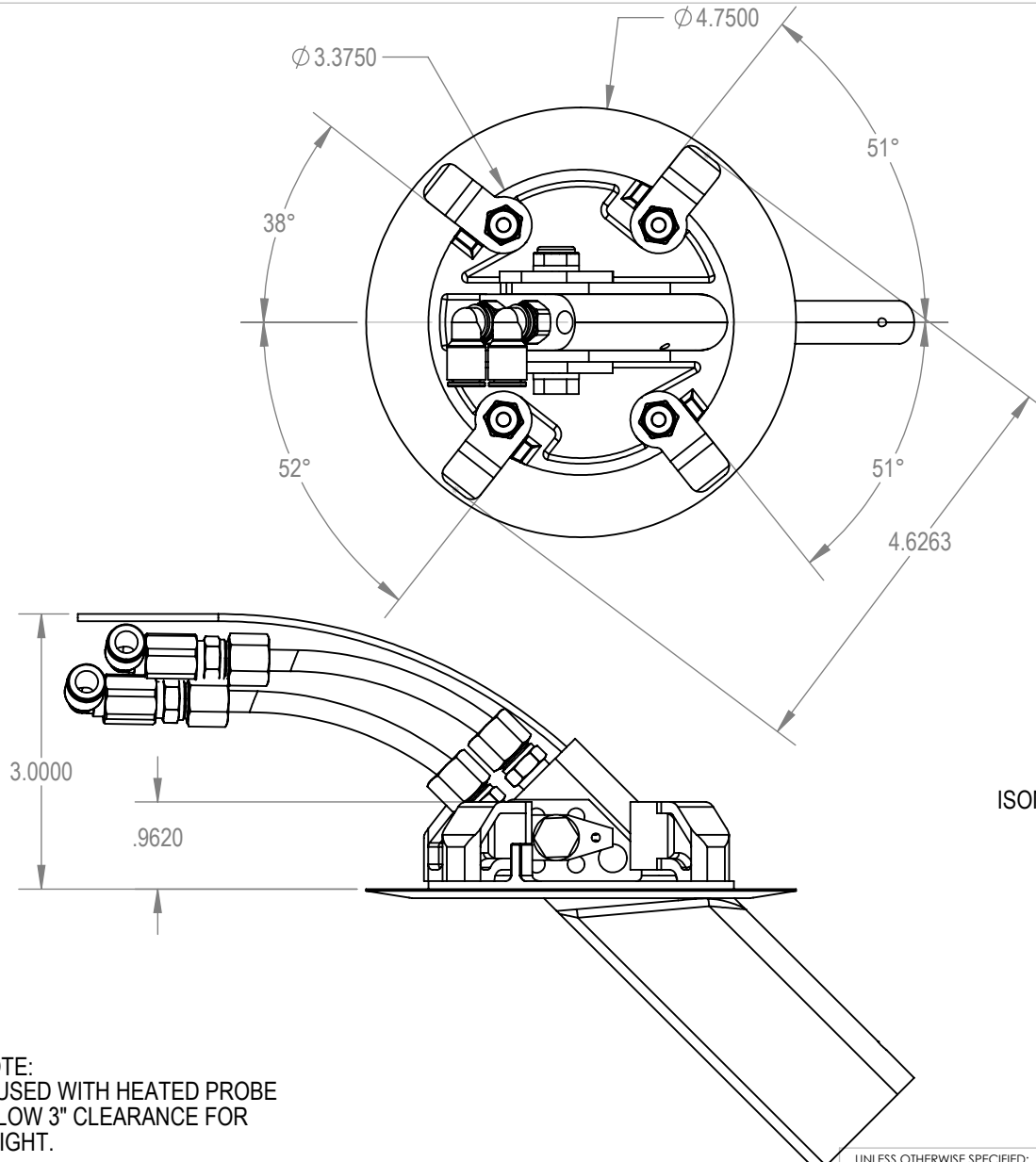

ISOMETRIC FRONT AND TOP VIEWS
1:2 SCALE

NOTE:
IF USED WITH HEATED PROBE
ALLOW 3" CLEARANCE FOR
HEIGHT.

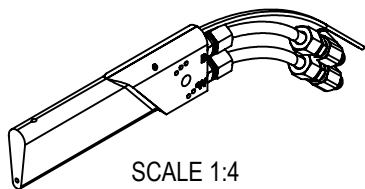

SCALE 1:4

UNLESS OTHERWISE SPECIFIED:
UNITS ARE IN INCHES AND
TOLERANCES ON DIMENSIONS
ARE IN INCHES

- .X = $\pm .03$
- .XX = $\pm .01$
- .XXX = $\pm .005$
- DEG. = $\pm 1^\circ$
- X/X = $\pm 1/16$

PROPRIETARY AND CONFIDENTIAL

THE INFORMATION CONTAINED IN THIS
DRAWING IS THE SOLE PROPERTY OF
DEPOTSTAR. ANY REPRODUCTION IN
PART OR AS A WHOLE WITHOUT THE
WRITTEN PERMISSION OF DEPOTSTAR IS
PROHIBITED.

DRAWN:	ARV	PROJECT:	AOA-4046
DATE:	7/12/2012	TITLE:	INSTALLATION SPECS FOR 3 1/2" PLATE
SHEET:	1	PART #	INSTALLATION SPECS
SCALE:			
SIZE:	A		
FINISH:			
MATERIAL:			

